

Pedestrian stacker truck 1.4 ton

BT staxio

W-series

SWE140S



Pedestrian stacker straddle version

Specification for stacker trucks					SWE140S
Identification	1.1	Manufacturer			BT
	1.2	Model			SWE140S
	1.3	Drive			Electric
	1.4	Operator type			Stand on/pedestrian
	1.5	Load capacity/rated load	Q	kg	1400
	1.6	Load centre	c	mm	600
	1.8	Load distance, centre of support arm wheel to face of forks	x	mm	758
	1.9	Wheelbase	y	mm	1443
	Weight	2.1	Service weight including battery		kg
2.2		Axle load, with load, drive/castor/ support arm wheel		kg	510/625/1774
2.3		Axle load, without load, drive/castor/ support arm wheel		kg	360/630/519
Wheels	3.1	Drive/castor/fork wheel			Friction/Vulkollan®/Vulkollan®
	3.2	Wheel size, front		mm	Ø 230
	3.3	Wheel size, rear		mm	Ø 140/ Ø 85
	3.4	Additional wheel size		mm	Ø 125
	3.5	Wheels, number front/rear (x = driven wheels)			1x+2/2 or 4
	3.6	Track width, front	b ₁₀	mm	585
	3.7	Track width, rear	b ₁₁	mm	985*
Dimensions	4.2	Height, mast lowered	h ₁	mm	1946
	4.3	Free lift	h ₂	mm	1666
	4.4	Lift	h ₃	mm	4060
		Lift height	h ₂₃	mm	4100
	4.5	Height, mast extended	h ₄	mm	5056
	4.9	Height of tiller in drive position, min./max. pedestrian	h ₁₄	mm	869/1294
	4.10	Height of support arm	h ₁₀	mm	140 or 93
	4.15	Height, fork lowered	h ₁₃	mm	50
	4.19	Overall length	l ₁	mm	2041
	4.20	Length to face of forks, without platform	l ₂	mm	891
	4.21	Overall width	b ₁ / b ₂	mm	790/1172*
	4.22	Fork dimensions	s/e/l	mm	40/100/1150
	4.25	Width over forks	b ₅	mm	250-890
	4.26	Distance between support arms	b ₄	mm	900*
	4.32	Ground clearance, centre of wheelbase	m ₂	mm	40/32,5
4.33	Aisle width for pallets 1000x1200 crossways	A _{st}	mm	2517	
4.34	Aisle width for pallets 800x1200 lengthways	A _{st}	mm	2396	
4.35	Turning radius	W _B	mm	1600	
Performance data	5.1	Travel speed, with/without load		km/h	6,0/6,0
	5.2	Lift speed, with/without load		m/s	0,17/0,33
	5.3	Lowering speed, with/without load		m/s	0,45/0,45
	5.8	Max. gradeability, with/without load ¹⁾		%	8/12
	5.9	Acceleration time (over 10 m)		s	7,1
	5.10	Service brake			Electromagnetic
Electric motor	6.1	Drive motor rating (S2 60min)			1,8
	6.2	Lift motor rating (S3 15%)		kW	3
	6.4	Battery voltage, nominal capacity K _s		V/Ah	24/300
	6.5	Battery weight		kg	195-270
	6.6	Energy consumption acc to VDI cycle		kWh/h	1,078
	Others	8.1	Type of drive control		
8.4		Sound level at the driver's ear according to EN 12 053		dB (A)	66

1) Measured according to company standard.

*) Further alternatives are available and will produce other values.

Data is based on standard truck and small battery.

All data are based on table configuration. Other configurations may give other values.

Truck performance and dimensions are nominal and subject to tolerances.

Toyota Material Handling Manufacturing Sweden AB products and specifications are subject to change without notice.

Battery dependent dimensions

Dimensions				SWE140S			
				Battery		Lift out	
						S	L
1.9	Wheelbase	y	mm	1443	1540		
4.19	Overall length	l_1	mm	2041	2138		
4.20	Length to face of forks	l_2	mm	891	988		
4.33	Aisle width for pallets 1000x1200 crossways	A_{st}	mm	2517	2615		
4.34	Aisle width for pallets 800x1200 lengthways	A_{st}	mm	2396	2494		
4.35	Turning radius	W_a	mm	1600	1698		
6.4	Battery voltage, nominal capacity K_5		V/Ah	24/300	24/500		
6.5	Battery weight, min.—max.		kg	195-310	345-405		

Mast dimensions

Mast			Duplex Tele Panoramic View					Duplex HiLo					Triplex HiLo								
SWE140S	h_{23}	Lift height ($h_{13}+h_3$)	mm	2300	2750	3250	3650	4100	2300	2450	2750	3250	3650	4100	3250	3650	3900	4100	4450	4750	5350
	h_3	Lift	mm	2210	2660	3160	3560	4010	2210	2360	2660	3160	3560	4010	3160	3560	3810	4010	4360	4660	5260
	h_1	Height, mast lowered	mm	1737	1962	2212	2412	2637	1736	1811	1961	2211	2411	2636	1662	1796	1879	1946	2062	2162	2362
	h_2	Free lift, ground to top of forks	mm	—	—	—	—	—	1256	1332	1482	1732	1932	2156	1194	1328	1410	1478	1594	1694	1894
	h_4	Height, mast extended	mm	2892	3342	3842	4242	4692	2891	3041	3341	3841	4241	4691	3816	4218	4467	4668	5016	5316	5916

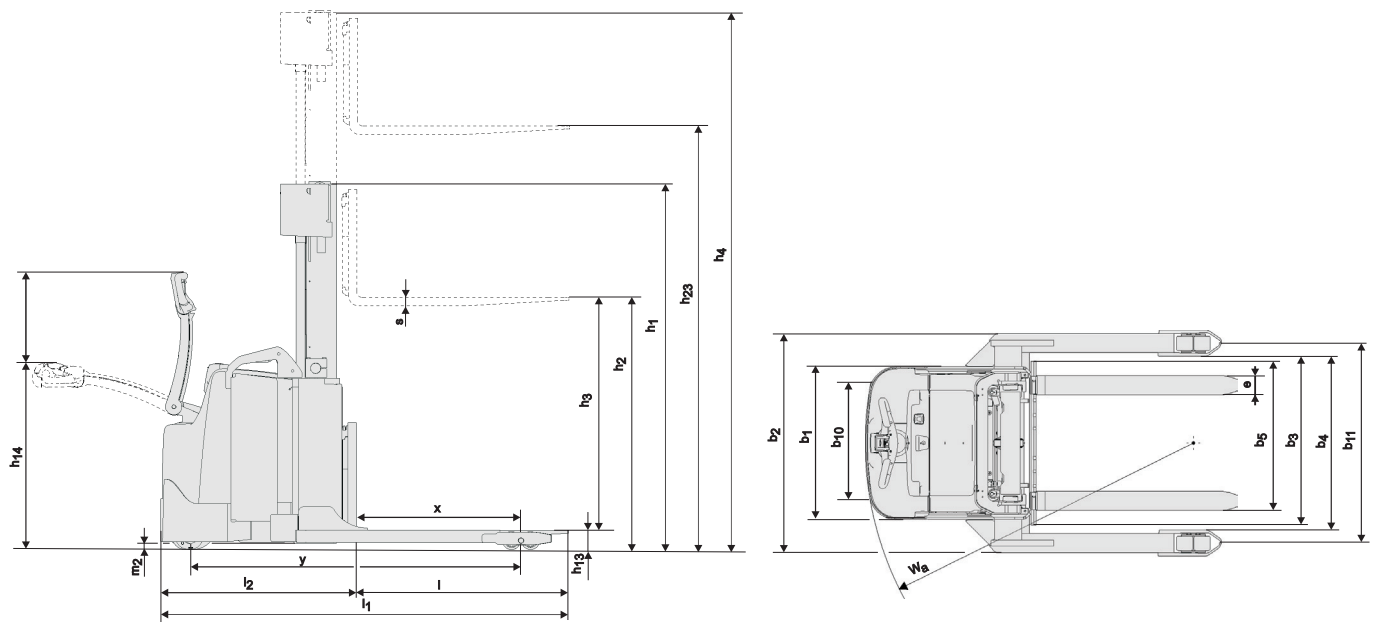

Truck features:

- BT Powertrak traction system
- Optimized Truck Performance
- Fingertip controls
- Electronic braking system
- Electronic speed control
- Operator safety
- Storage compartments
- Automatic switch-off
- Programmable performance
- Easy access for maintenance
- Sensilift
- Toyota I_site: truck fleet management system (option)
- Hydraulic oil for low temperatures (option)

