

RRE120M
RRE140M
RRE160M



The Reflex M-series are reach trucks available with capacity up to 1600kg and lift heights up to 8.5 metres. Each truck is configured to provide the optimum chassis / battery / mast combination according to the requirements of the application.



Technical Details		RRE120M			RRE140M			RRE160M		
Power unit		electric								
Operating type		ride on								
Rated capacity	kg	1200			1400			1600		
Load centre	mm	600			600			600		
Weight without battery	kg	1915 (h ₃ =4800mm)			2040 (h ₃ =5400mm)			2575 (h ₃ =8500mm)		
Max. axle load front without/with rated load	kg	1430/3330			1640/3930			2118/4685		
Max. axle load rear, without/with rated load	kg	1630/1340			1690/1300			2003/1580		
Wheel type, front/rear		polyurethane			polyurethane			polyurethane		
dimension, front/rear	mm	Ø 285/310			Ø 285/310			Ø 285/310		
Tilting system	°	Mast tilt, +2/-0.5			Fork tilt, +4/-2			Fork tilt, +4/-2		
Travel speed, without/with rated load	km/h	11.2/10.1			11.2/10.0			11.2/10.0		
Lift speed, without/with rated load	m/s	0.42/0.29			0.42/0.27			0.42/0.25		
Lowering speed, without/with rated load	m/s	0.47/0.47			0.44/0.50			0.44/0.50		
Gradient, without/with rated load	%	15/10			15/10			15/10		
Acc. time, 0—9 m, without/with rated load	s	4,6/5,2			4,6/5,2			4,6/5,2		
Service brake		electric								
Parking brake		autom. electr. magnetic								
Drive motor rating (S2 60')	kW	7,5			7,5			7,5		
Lift motor rating (S3 15%)	kW	7.4			7.4			7.4		
Steering system		electronic								
Speed control, number of steps		transistor, stepless								
Number of steering wheel turnings		endless								

Dimensions, mm		RRE120M			RRE140M			RRE160M		
y	Wheel base	1434			1434			1434		
h ₆	Height of cab	2166			2166			2166		
h ₈	Height of support arm	262			262			262		
b ₁₄	Width of support arm	120			120			120		
h ₁₃	Height of lowered fork	40			40			40		
b ₁	Chassis, width	1120			1120			1120		
e	Fork width	100			100			100		
l	Fork length	1000, 1150			1000, 1150			1000, 1150		
b ₅	Width across fork									
	without sideshift	250—720			250—720			250—720		
	with sideshift	250—600			250—600			250—600		
b ₄	Width between support arms	880			880			880		
m ₁	Floor clearance	70 ¹⁾			70 ¹⁾			70 ¹⁾		
W _a	Turning radius	1649			1649			1649		
l ₇	Truck length excl. fork	1808			1808			1808		

Dimensions — Battery compartment				RRE120M			RRE140M			RRE160M		
x	Front axle to fork face											
		without sideshift	mm	449 ²⁾	384 ²⁾	294 ²⁾	418	353	263	400	335	245
		with sideshift	mm	394	329	239	380	315	225	362	297	207
	with rollerbed, incl. sideshift	mm	369	304	214	355	290	200	337	272	182	
l ₂	Truck length incl. fork front face	without sideshift	mm	1182	1247	1337	1231	1296	1386	1249	1314	1404
		with sideshift	mm	1237	1302	1392	1269	1334	1424	1287	1352	1442
	Battery capacity, 48 V	Ah		292—	360—	480—	292—	360—	480—	292—	360—	480—
				300	450	600	300	450	600	300	450	600
	Battery weight, min.	kg		510	610	780	510	610	780	510	610	780
	Depth	mm		275	340	430	275	340	430	275	340	430

- 1) 15mm under studs
2) Based on Triplex mast

Truck performance and dimensions are nominal and subject to tolerances.
BT Products AB products and specifications are subject to change without notice.
All data is based on VDI 2198.

Mast, mm																
RRE120M																
h_3	Lift height	3350	3750	4150	4400	4500	4800	5400	5700	6000	6300	6750	7000	7500	8000	8500
Duplex Tele																
h_1	Height of mast, min.	2194	2404	2604												
h_2	Free lift	—	—	—												
h_4	Height of mast, max.	3849	4259	4659												
Duplex Hi-Lo																
h_1	Height of mast, min.	2194	2404	2604												
h_2	Free lift	1725	1925	2125												
h_4	Height of mast, max.	3849	4259	4659												
Triplex Hi-Lo																
h_1	Height of mast, min.			1930		2047	2147	2347		2647						
h_2	Free lift			1457		1574	1674	1874		2174						
h_4	Height of mast, max.			4654		5004	5304	5904		6504						

Mast, mm																
RRE140M																
h_3	Lift height	3350	3750	4150	4400	4500	4800	5400	5700	6000	6300	6750	7000	7500	8000	8500
Triplex Hi-Lo																
h_1	Height of mast, min.				2057		2190	2390	2490		2690					
h_2	Free lift				1416		1549	1749	1849		2049					
h_4	Height of mast, max.				5040		5440	6040	6340		6940					

Mast, mm																
RRE160M																
h_3	Lift height	3350	3750	4150	4400	4500	4800	5400	5700	6000	6300	6750	7000	7500	8000	8500
Triplex Hi-Lo																
h_1	Height of mast, min.				2057		2190	2390	2490		2732	2981	3064	3231	3398	3564
h_2	Free lift				1416		1549	1749	1849		2091	2340	2423	2590	2757	2923
h_4	Height of mast, max.				5040		5440	6040	6340		6940	7390	7640	8140	8640	9140

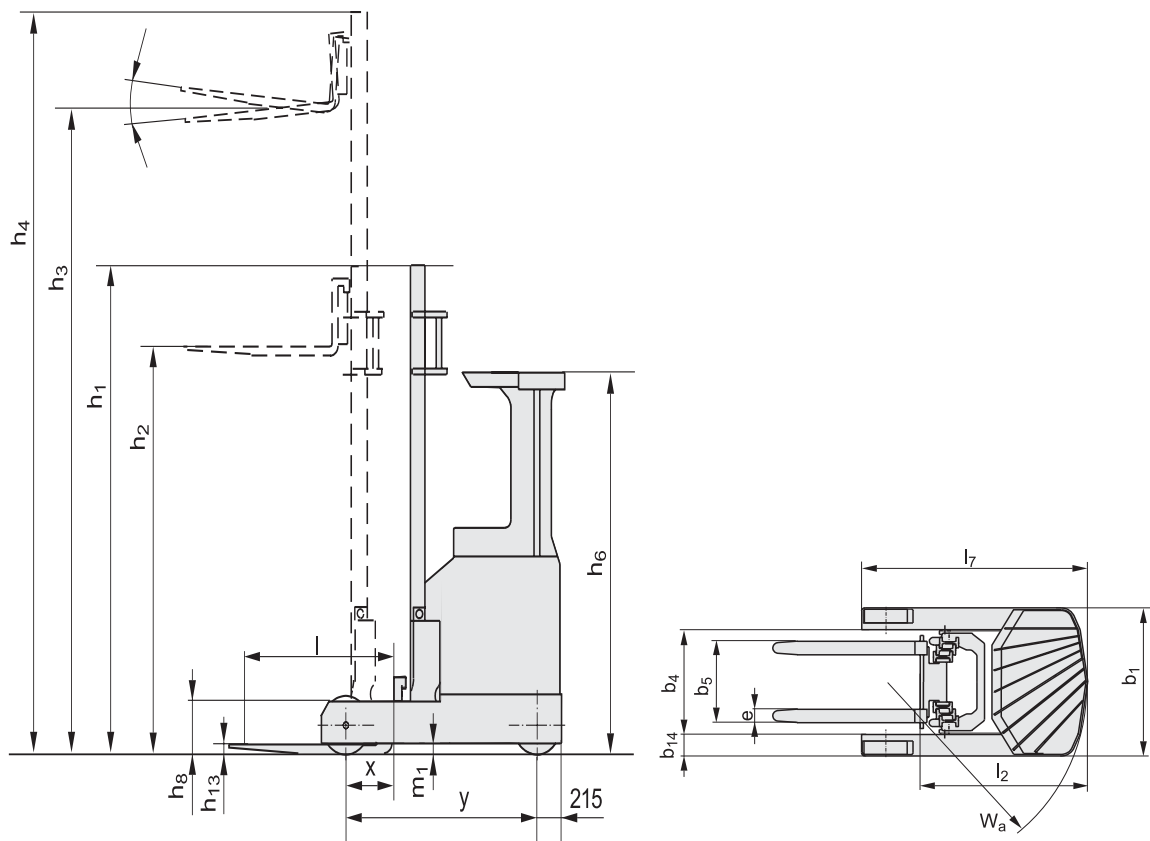



- Excellent driver ergonomics, with adjustable seat, pedals and BT Control console, with electronic control of all hydraulic functions.
- Panoramic vision through clear view mast and overhead guard. Visibility window for improved rear view.
- Easy selection of performance parameters. Standard set-up choices available. Up to 100 PIN numbers available to provide access control, and no keys needed. Restricting operation to only authorized drivers.
- Electronic regenerative braking (motor braking, pedal braking or change of drive direction). Programmable to suit the driver.
- State-of-the-art electronic system, incorporating Can and Mosfet technology — requiring less wiring and giving greater reliability.
- E-bar. Universal mount for warehouse management devices such as PC:s, terminals, bar code readers etc.

Truck features	RRE120M	RRE140M	RRE160M
Adjustable fork width	S	S	S
Tilting forks	—	S	S
Choice of cab widths	O	O	O
Controls and instruments			
Fingertip controls	S	S	S
Electronic height indicator	—	—	O
Height pre-selector	—	—	O
Driving features			
360° progressive steering	S	S	S
Automatic deceleration	S	S	S
Electronic braking system	S	S	S
Electronic speed control	S	S	S
Safety features			
Automatic parking brake	S	S	S
BT Access Control	S	S	S
Clear-view mast	S	S	S
Clear-view overhead guard	S	S	S
Programmable performance	S	S	S
Drivers compartment features			
Adjustable pedals	S	S	S
Low step-in	S	S	S
On-board data terminal mount (E-bar)	S	S	S
Maintenance features			
Fault diagnosis facility	S	S	S
History fault log	S	S	S
Battery management features			
Battery status indicator	S	S	S
Side-ways battery change	O	O	O
Special applications			
Coldstore version	O	O	O

S = Standard feature

O = Optional feature

— = Not available

BT
 SE-595 81 Mjölby Sweden
 Tel: +46 (0)142 860 00
 Fax: +46 (0) 142 866 00
 Email: info@bt-forklifts.com
 www.bt-forklifts.com

