



The Veflex is equipped with everything needed for heavy duty and high performance very narrow aisle handling. As a special version, the Veflex VRE125 is available with a duplex mast, allowing a great forward view. Furthermore, a redesign of the mast fitting has resulted in an improved visibility over the forks at low level.



Technical Details		VRE125
Power unit		electrical, battery
Operating type		ride on
Rated capacity	kg	1250
Load centre	mm	600
Weight without battery	kg	3640 ¹⁾
Wheel type		polyurethane
Wheel dimension, fork side	mm	230x110; 230x85
Wheel dimension, drive wheel side	mm	350x130
Number of wheels, fork side		4
Number of wheels, drive wheel side		1
Travel speed, without/with rated load	km/h	9/9
Lift speed, without/with rated load	m/s	0.37/0.29
Lowering speed, without/with rated load	m/s	0.48/0.50
Service brake		electro-regenerative
Parking brake		electro-mechanical
Drive motor/Intermittent rating	kW/%	7.5/60
Lift motor/Intermittent rating	kW/%	14/15
Battery weight	kg	940—1400
Battery (5h discharge)	V/Ah	48/480—900
Battery (5h discharge)	kWh	25.9; 32.4; 38.9
Steering system		electronic power steering
Speed control, number of steps		electronical, stepless

Dimensions, mm		VRE125
y	Wheel base	1750/1900/2050
b ₁₀	Track width front c/c	1038/1148/1248
h ₆	Height of cab	2266
h ₇	Height of driver's seat	1100
h ₁₃	Height of lowered fork	80
l ₁	Total truck length	3185/3335/3485 ²⁾
l ₈	Front axle to boom pivot	820
b ₁	Chassis, width	1270/1420/1520
s	Fork thickness	40
e	Fork width	120
l	Fork length	600—1600
b ₅	Width across fork	525—1160 ³⁾
m ₂	Floor clearance mid wheelbase	60
W _a	Turning radius	1960/2110/2260

1) h₂₃ = 4100mm, b₁ = 1420mm, l₁ = 3185mm

2) With boom length 650mm

3) Depending on boom length

Mast, mm		VRE125					
h_{23}	Total lift height	3600	4000	4850	5650	6300	6700
Duplex Tele							
h_1	Height of mast, min.	2920	3120	3553	3953	4487	4687
h_4	Height of mast, max.	4685	5085	5950	6750	7618	8018

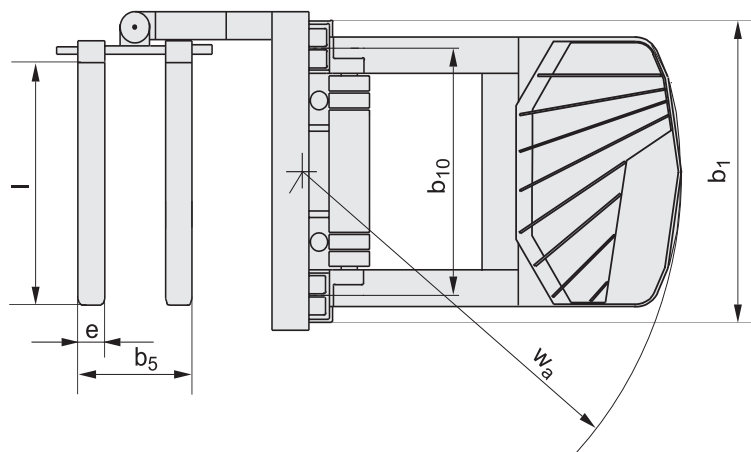
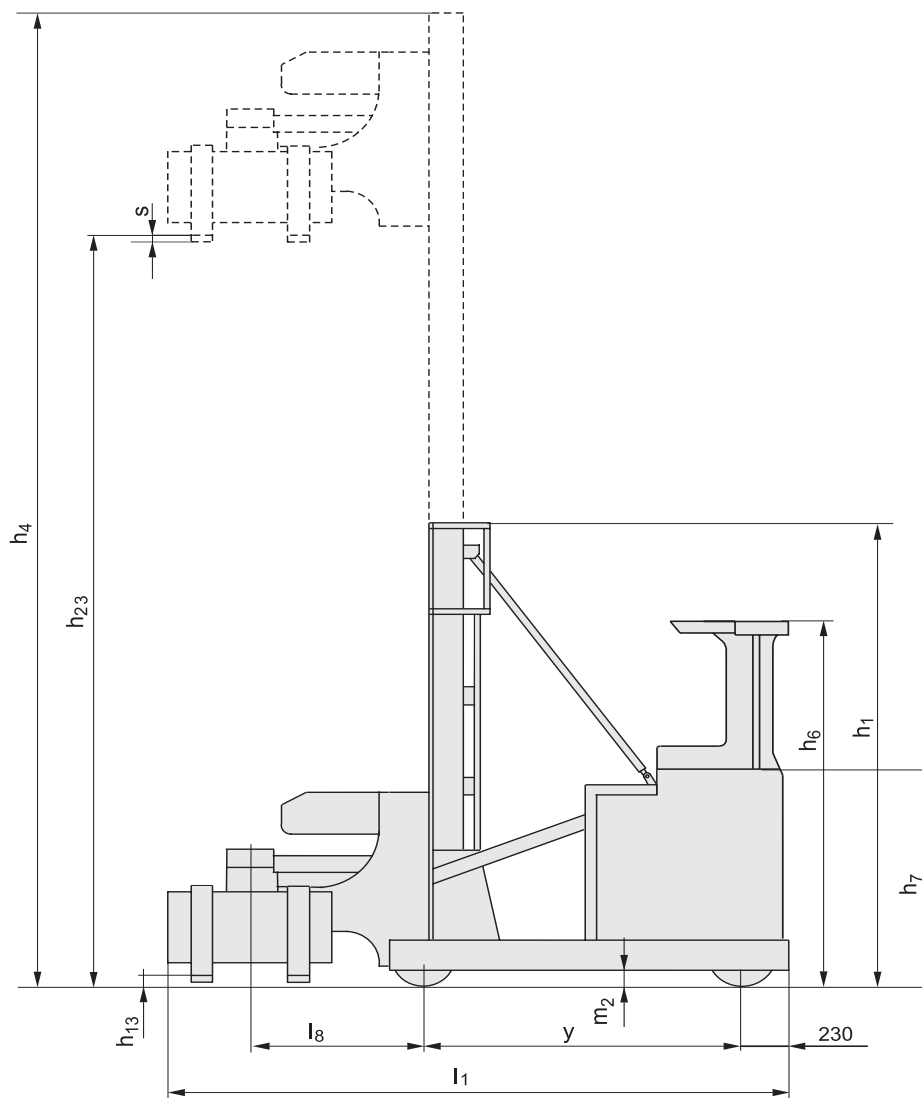

Truck performance and dimensions are nominal and subject to tolerances.
 BT Products AB products and specifications are subject to change without notice.
 All data is based on VDI 2198.



- The turret head trucks are able to pick up the load from the floor and can handle the pallets from the short or the long side.
- The VRE125 has a lifting capacity of 1250 kg and a maximum standard lift height of 6,7 metres. The aisle width varies from a narrow 1420 mm to more than 2 metres depending on the load length
- Very fast acceleration rate and a travel speed of max. 9 km/h combined with the unique BT Optipace system (adapted speed, acceleration and braking to fork height) allowing outstanding and at the same time also safe performance.
- The standard electronic height indicator shows the fork height above ground and is helping the operator with positioning.
- E-bar. Universal mount for warehouse management devices such as PC:s, terminals, bar code readers etc.

Truck features	VRE125
Adjustable fork width	S
Choice of chassis widths	S
Fork spreader	O
Tilting forks	O
Wire/rail guidance	O
Controls and instruments	
Electronic height indicator	S
Power/electronic steering	S
Steering direction indicator	S
Weight indicator	S
Driving features	
360° progressive steering	S
Automatic deceleration	S
Electronic braking system	S
Electronic speed control	S
Safety features	
Automatic parking brake	S
Clear-view overhead guard	S
Programmable performance	S
Drivers compartment features	
Adjustable pedals	S
Adjustable seat	S
Adjustable steering wheel	S
On-board data terminal mount (E-bar)	S
Maintenance features	
Fault diagnosis facility	S
History fault log	S
Battery management features	
Battery status indicator	S
Side-ways battery change	S
Special applications	
Coldstore version	O

S = Standard feature

O = Optional feature

— = Not available