



The Veflex is a very narrow aisle truck, based on the successful technology of the Reflex reach truck. It is equipped with everything needed for heavy duty and high performance very narrow aisle handling.



Technical Details		VRE150
Power unit		electrical, battery
Operating type		ride on
Rated capacity	kg	1500
Load centre	mm	600
Weight without battery	kg	4050 ¹⁾
Wheel type		polyurethane
Wheel dimension, fork side	mm	230x110; 230x85
Wheel dimension, drive wheel side	mm	350x130
Number of wheels, fork side		4
Number of wheels, drive wheel side		1
Travel speed, without/with rated load	km/h	12/12 — 9/9 ²⁾
Lift speed, without/with rated load	m/s	0.37/0.29
Lowering speed, without/with rated load	m/s	0.48/0.50
Service brake		electro-regenerative
Parking brake		electro-mechanical
Drive motor/Intermittent rating	kW/%	7.5/60
Lift motor/Intermittent rating	kW/%	14/15
Battery weight	kg	940—1400
Battery (5h discharge)	V/Ah	48/480—900
Battery (5h discharge)	kWh	25.9; 32.4; 38.9
Steering system		electronic power steering
Speed control, number of steps		electronical, stepless

Dimensions, mm		VRE150
y	Wheel base	1750/1900/2050
b ₁₀	Track width front c/c	1038/1148/1248
h ₆	Height of cab	2266
h ₇	Height of driver's seat	1100
h ₁₃	Height of lowered fork	80
l ₁	Total truck length	3185/3335/3485 ³⁾
l ₈	Front axle to boom pivot	820
b ₁	Chassis, width	1270/1420/1520
s	Fork thickness	40
e	Fork width	120
l	Fork length	600—1600
b ₅	Width across fork	525—1160 ⁴⁾
m ₂	Floor clearance mid wheelbase	60
W _a	Turning radius	1960/2110/2260

1) h₂₃ = 6100mm, b₁ = 1420mm, l₁ = 3335mm

2) 12/12 km/h for chassis width 1420mm and 1520mm when rail guided.

9/9 km/h for chassis width 1270mm, or chassis width 1420mm and 1520mm when wire guided.

3) With boom length 650mm

4) Depending on boom length

Mast, mm		VRE150										
h_{23}	Total lift height	4300	4900	5500	6100	7000	7600	8200	8800	9400	10000	11000
Triples Hi-Lo												
h_1	Height of mast, min.	2535	2735	2935	3135	3570	3770	3970	4170	4505	4705	5035
h_2	Free lift	1490	1690	1890	2090	2524	2724	2924	3124	3458	3658	3990
h_4	Height of mast, max.	5295	5895	6495	7095	7995	8595	9195	9795	10395	10995	11995

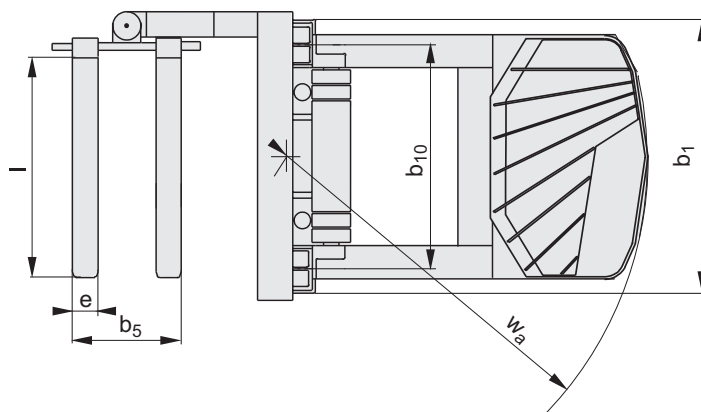
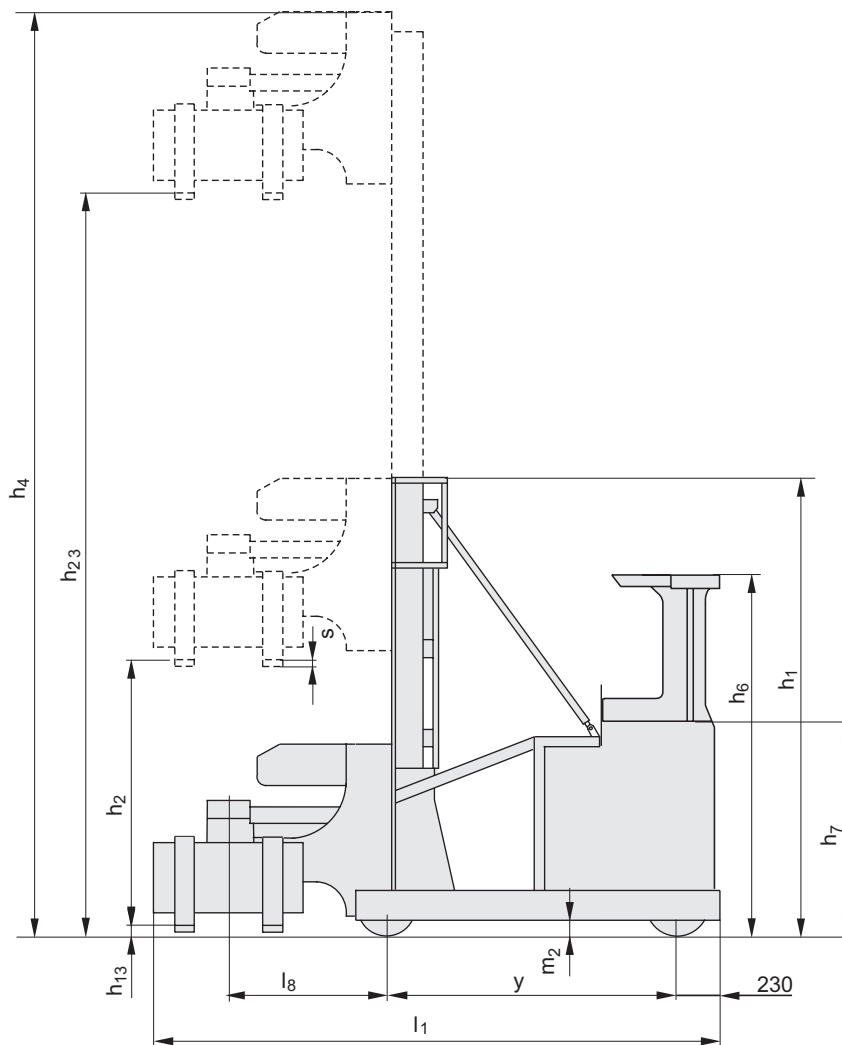



- The turret head trucks are able to pick up the load from the floor and can handle the pallets from the short or the long side.
- Very fast acceleration rate and a travel speed of max. 12 km/h (rail guided truck) combined with the unique BT Optipace system allowing outstanding and at the same time also safe performance.
- The standard electronic height indicator shows the fork height above ground and is helping the operator with positioning.
- Regenerative lowering in combination with the fully electronic controlled fork functions and a large battery compartment allowing longer shifts or — due to the very fast cycle time — more pallets in the same shift.
- E-bar. Universal mount for warehouse management devices such as PC:s, terminals, bar code readers etc.



Truck features	VRE150
Adjustable fork width	S
Choice of chassis widths	S
Fork spreader	O
Tilting forks	O
Wire/rail guidance	O
Controls and instruments	
Electronic height indicator	S
Power/electronic steering	S
Steering direction indicator	S
Weight indicator	S
Driving features	
360° progressive steering	S
Automatic deceleration	S
Electronic braking system	S
Electronic speed control	S
Safety features	
Automatic parking brake	S
Clear-view overhead guard	S
Programmable performance	S
Drivers compartment features	
Adjustable pedals	S
Adjustable seat	S
Adjustable steering wheel	S
On-board data terminal mount (E-bar)	S
Maintenance features	
Fault diagnosis facility	S
History fault log	S
Battery management features	
Battery status indicator	S
Side-ways battery change	S
Special applications	
Coldstore version	O

S = Standard feature

O = Optional feature

— = Not available